

# SET UP

## SPYDER SRX-MID

### Serpent

RACE **National BRCA Round 4** DATE **04.06.2015** TRACK **EPR**

DRIVER **Tony Evdoka** TRACK TEMP **10** AIR TEMP **18c**

INDOOR  TIGHT  MEDIUM  LOW BITE  HIGH BITE

OUTDOOR  OPEN  MED BITE  V/Low Grip

TRACK DESCRIPTION

SMOOTH  HARD PACKED  GRASS  ASTRO-TURF  CLAY

ROUGH  BLUE GROOVE  CARPET  MULTI/SURFACE  Concrete

### REAR DIFFERENTIAL

BALL DIFFERENTIAL DIFFERENTIAL HEIGHT

GEAR DIFF **10000** cst  HIGH  MED  LOW

### GEAR RATIO

SPUR GEAR	TEETH	<b>78 - kit</b>
PINION	TEETH	<b>24</b>
FINAL DRIVE RATIO		

### ELECTRONICS

BATTERY: SADDLE  SHORTY

BRAND **Orion** CAPACITY **4500 - 90c**

MOTOR

BRAND **Orion 6.5** TYPE **VST2** TIMING **0**

ESC

BRAND **Orion** TYPE **V10.1 Pro**

### SHOCK ABSORBERS

	FRONT	REAR
OIL	<b>550</b> cst	<b>450</b> cst
SPRING	<b>Blue</b>	<b>Orange</b>
LIMITERS (2)	<b>1.5</b> mm	<b>0</b> mm
LENGTH (3)	mm	mm
REBOUND (4)	<b>0</b> mm	<b>0</b> mm
BLADDER / SEAL (5)	<input checked="" type="checkbox"/> SEAL <input type="checkbox"/> BLADDER	<input checked="" type="checkbox"/> SEAL <input type="checkbox"/> BLADDER
SPRING BUCKET	<input checked="" type="checkbox"/> SHORT <input type="checkbox"/> LONG	<input checked="" type="checkbox"/> SHORT <input type="checkbox"/> LONG
PISTONS (1)	N° OF HOLES <b>2</b>	<b>2</b>
	DIAMETER <b>1.6</b> mm	<b>1.6</b> mm
TYPE		
<input type="checkbox"/> STOCK <input checked="" type="checkbox"/> CONICAL <input type="checkbox"/> SQUARE		

### FRONT ANTI-ROLL BARS REAR

0.9  1  1.1  Other  1.1  1.3  1.5  Other

### TIRES

FRONT	Controlled Tire	REAR
<b>Schumacher</b>	<input checked="" type="checkbox"/>	<b>Schumacher</b>
<b>Cut Stagger</b>	MAKE	<b>Mini Spike</b>
<b>Yellow</b>	TYPE	<b>Yellow</b>
<b>None</b>	COMPOUND	<b>Ballistic Buggy</b>
<b>Cut Narrow</b>	INSERT TYPE	<b>Standards</b>
<b>None</b>	WHEELS	<b>Standards</b>
	ADDITIVE	<b>None</b>

### AERODYNAMIC CONFIGURATION

BODY BRAND **Kit** TYPE **Kit**

REAR WING BRAND **RudeBits** TYPE **R1 4deg**

REAR WING WIDTH **6.5" - 160mm**

REAR WING LIP **5mm** mm

REAR WING ANGLE 0  2  4  6  8

FRONT WING YES  NO

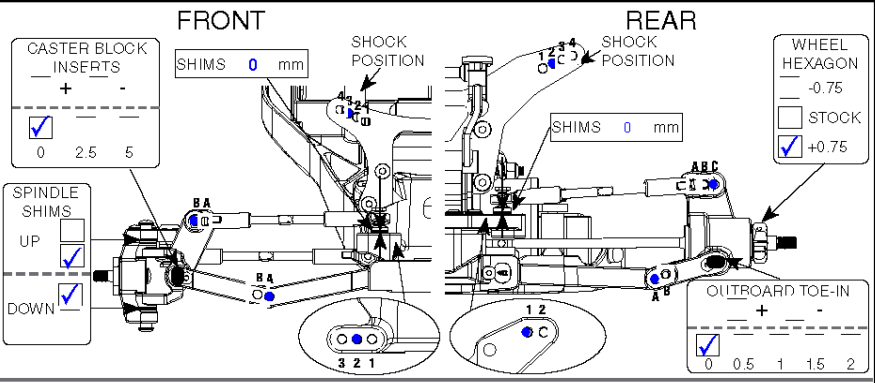

FRONT BULKHEAD <input checked="" type="checkbox"/> STOCK <input type="checkbox"/> ALU <input type="checkbox"/> BRASS	FRONT CASTER BLOCK <input checked="" type="checkbox"/> STOCK <input type="checkbox"/> ALU	WHEEL BASE	REAR UPRIGHT <input type="checkbox"/> STOCK <input checked="" type="checkbox"/> ALUMINUM
INSERT <input type="checkbox"/> 20° <input checked="" type="checkbox"/> 25° <input type="checkbox"/> 30°	<b>0</b> mm		<b>2</b> mm

BUMP STEER <b>1</b> mm	ACKERMAN PLATE <input checked="" type="checkbox"/> STOCK <input type="checkbox"/> BRASS	REAR FR TOE BLOCK <input checked="" type="checkbox"/> UP <input type="checkbox"/> DOWN <input type="checkbox"/> WIDE <input type="checkbox"/> NARROW <input checked="" type="checkbox"/> STOCK <input type="checkbox"/> BRASS
	<input type="checkbox"/> OPT.1 <input checked="" type="checkbox"/> OPT.2 <input type="checkbox"/> OPT.3	REAR RR TOE BLOCK <input type="checkbox"/> UP <input type="checkbox"/> WIDE <input checked="" type="checkbox"/> DOWN <input type="checkbox"/> NARROW

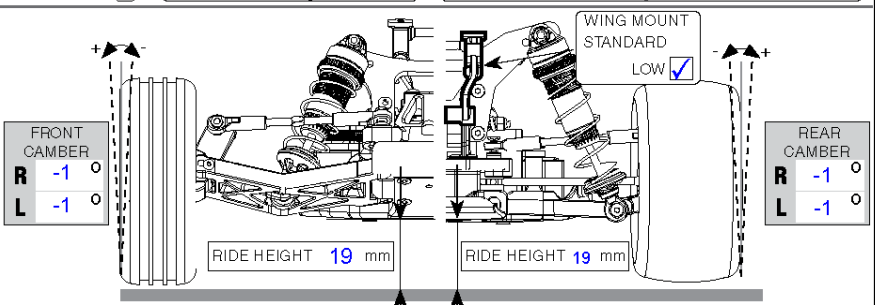

### WEIGHT DISTRIBUTION

CAR WEIGHT **1780** grams

WEIGHT BIAS FR **38%** RR **62%**

BATTERY LOCATION **Forward** mm

### BALLAST WEIGHT

YES  NO

FRONT TOE **0** REAR TOE **3**

### REMARKS

70g Under Speedo - also 46g under Lipo  
SCT 500316 (C-Hub) - 500317 (Steering Block)